

## Elevation

Arik Levy 2009

**FLORA** 



In his Paris studio, Arik Levy developed the Elevation concept. You can enter a green oasis in the middle of a group of these elements. So what is the idea behind this product? You are face to face with the world of plants, with your own reflection in the middle, or the fascinating honeycomb structure which allows the tendrils to climb and twist. Elevation is the green life, giving access to nature on a different level.

**FLORA Wilh. Förster**  
GmbH & Co. KG

Schmidtsiepen 3  
58553 Halver  
Germany

Phone +49 (0)2353 9117-0  
Fax +49 (0)2353 9117-17  
E-Mail [info@flora.biz](mailto:info@flora.biz)  
Internet [www.flora.biz](http://www.flora.biz)

## Elevation

Arik Levy 2009

# FLORA

Planter in four sizes, aluminium sheet, powder coated white other colours on request, steel legs, zinc-plated and powder coated, various accessories

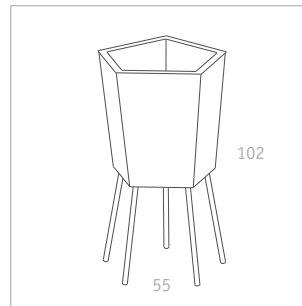

Elevation 60  
Volume planter 60 l  
Planting depth 57 cm  
Weight 10 kg

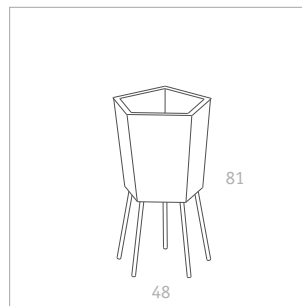

Elevation 50  
Volume planter 32 l  
Planting depth 51 cm  
Weight 8 kg

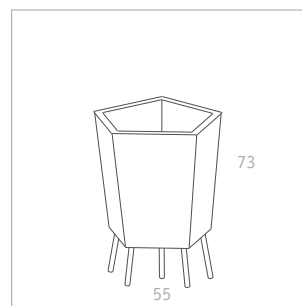

Elevation 40  
Volume planter 60 l  
Planting depth 57 cm  
Weight 7 kg

**FLORA Wilh. Förster**  
GmbH & Co. KG

Schmidtsiepen 3  
58553 Halver  
Germany

Phone +49 (0)2353 9117-0  
Fax +49 (0)2353 9117-17  
E-Mail [info@flora.biz](mailto:info@flora.biz)  
Internet [www.flora.biz](http://www.flora.biz)

## Elevation

Arik Levy 2009

# FLORA

Planter in four sizes, aluminium sheet, powder coated white other colours on request, steel legs, zinc-plated and powder coated, various accessories

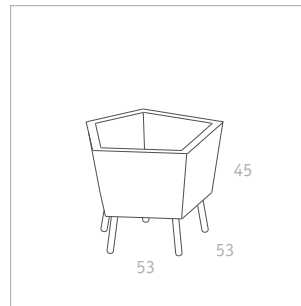

Elevation 30  
Volume planter 30 l  
Planting depth 29 cm  
Weight 7 kg



**FLORA Wilh. Förster**  
GmbH & Co. KG

Schmidtsiepen 3  
58553 Halver  
Germany

Phone +49 (0)2353 9117-0  
Fax +49 (0)2353 9117-17  
E-Mail [info@flora.biz](mailto:info@flora.biz)  
Internet [www.flora.biz](http://www.flora.biz)

## Elevation

Arik Levy 2009

# FLORA

Planter in four sizes, aluminium sheet, powder coated white other colours on request, steel legs, zinc-plated and powder coated, various accessories

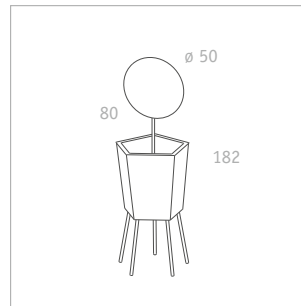

Mirror, super polished stainless steel,  $\varnothing$  50 cm x 3 mm  
Weight 2,6 kg

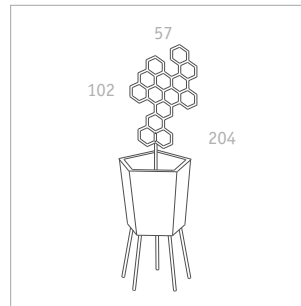
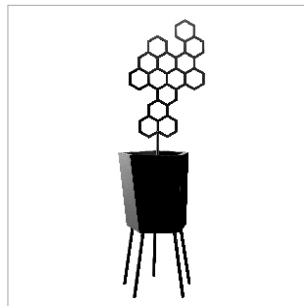

Trellis  
Weight 2,9 kg

**FLORA Wilh. Förster**  
GmbH & Co. KG

Schmidtsiepen 3  
58553 Halver  
Germany

Phone +49 (0)2353 9117-0  
Fax +49 (0)2353 9117-17  
E-Mail [info@flora.biz](mailto:info@flora.biz)  
Internet [www.flora.biz](http://www.flora.biz)

## Planting inserts

Removable planter inserts made of high-quality aluminium are a standard fitting for every FLORA plant container, only the intended use determines whether a water-permeable or a water-proof insert is the right choice, the double-wall design, which creates a layer of air between the plant container and the planter insert, ensures that the root system is protected against heat and frost

# FLORA



### Using plants outdoors

Ventilation slits for oxygen in the root systems, water reservoir, insulating air layer for protection against heat, drying out or frost



### Using plants indoors

Watertight, light aluminium, optionally with water reservoir and water level indicator

**FLORA Wilh. Förster**  
GmbH & Co. KG

Schmidtsiepen 3  
58553 Halver  
Germany

Phone +49 (0)2353 9117-0  
Fax +49 (0)2353 9117-17  
E-Mail [info@flora.biz](mailto:info@flora.biz)  
Internet [www.flora.biz](http://www.flora.biz)